

Huvema[®]
BLUE-LINE

ALLES VOOR DE WERKPLAATS



CATALOGUS
WERKPLAATSINRICHTING

☀ Huvema levert alles voor de werkplaats!

Goede prestaties beginnen met een professionele werkplaats!

Huvema biedt een compleet programma van producten voor een optimale werkplaatsinrichting.

Van machines tot compressoren, handgereedschap en kasten.

De specialisten van Huvema denken graag mee om de werkomgeving zo efficiënt en veilig mogelijk in te richten.

📖 Dit is Huvema

Als toonaangevende groothandel is Huvema al bijna 50 jaar actief in Nederland. Inmiddels leveren wij onze machines wereldwijd in meer dan 20 andere landen.

Huvema staat bekend om de uitstekende leverbetrouwbaarheid. Vanuit ons magazijn in Veghel kunnen wij meer dan 10.000 artikelen uit voorraad leveren!

Met onze specialisatie in de toelevering van machines en gereedschappen voor de metaalbewerkende industrie hebben wij een zeer goede reputatie in de markt opgebouwd.

Onze machines worden wereldwijd o.a. in werkplaatsen en bij vak- en praktijkopleidingen succesvol ingezet.

Onze klanten waarderen de goede prijs/kwaliteitverhouding van onze producten en onze flexibiliteit. De machines van Huvema zijn leverbaar via een uitgebreid dealernetwerk.

In onze webshop verkopen wij een ruim assortiment aan producten voor de werkplaats. U kunt hierbij denken aan handgereedschap, werkplaatsinrichting, compressoren etc. Deze artikelen bieden wij aan naast ons eigen programma metaalbewerkingsmachines van het merk Huvema.

Voor installatie, reparatie en onderhoud kunnen onze klanten rekenen op de vakkundige service van onze technische dienst. Kom gerust zelf eens kijken in onze showrooms in Veghel. Wij kunnen op onze locatie alle machines werkend demonstreren!

🎯 Kernactiviteiten

Verkoop van:

- Huvema metaalbewerkingsmachines
- iTools verspanende gereedschappen
- Pard handgereedschappen
- Huvema Blue-Line werkplaatsartikelen
- Overige werkplaatsartikelen





Online bestellen

In de Huvema webshop vindt u een ruime keus aan artikelen voor hobby, werkplaats, bouw en constructie! In principe is alles uit voorraad leverbaar. Wij streven er dan ook naar dat u de bestelling de volgende werkdag in huis heeft. Contant betalen en pinnen is mogelijk bij afhalen in Veghel.

Online kunt u alle producten en de relevante informatie eenvoudig inzien. Bestel veilig online uw werkplaatsbenodigdheden in onze webshop.

Exclusief dealer account

Dealers kunnen zich registreren met een exclusief dealer account.

- Uw dealerkorting wordt automatisch berekend
- Op orders via shop.huvema.nl berekenen wij u geen verzendkosten
- Direct de juiste prijs-, voorraad- en leverinformatie
- Levering op elk door u gewenst adres (dus geen extra vrachtkosten!)
- Inzicht in bestellingen en bestelhistorie
- Gemakkelijk en veilig online betalen
- Achteraf betalen mogelijk
- Bestelde producten afhalen in Veghel mogelijk
- Pinnen/contant betalen bij afhalen mogelijk

Houdt u er rekening mee dat alleen onze bestaande dealers, wederverkopers en distributeurs een goedgekeurd dealer account krijgen. Wilt u onze producten in uw verkoopprogramma opnemen en bent u nog geen dealer? Neem dan contact op met ons sales team.

Technische Dienst

Wij hebben een eigen technische dienst. Bij levering van de machines bieden wij u graag de mogelijkheid de machines te laten installeren en aan te laten sluiten door onze medewerkers. Onze technici zijn specialisten die iedere machine goed kennen.

Reparaties

Is uw product na de garantieperiode defect of is er een servicebeurt nodig? Ook dan kunt u op ons rekenen! Bij reparaties buiten de garantieperiode wordt het uurloon en de prijs van de onderdelen in rekening gebracht. Onze technische dienst voert zowel bij u op locatie als eventueel in onze eigen werkplaats de benodigde werkzaamheden vakkundig uit.



PRODUCTOVERZICHT



Boormachines

- V-snaaraangedreven
- Tandwielboormachines
- Boormachines met kruistafel
- Radiaalboormachines



Schroefcompressoren

- Compressor
- Compressor met tank
- Compressor tank en droger



Freesmachines

- Boorfreesmachines
- Werkplaats
- Type Bridgeport
- Type Deckel
- Type Huron
- Type Bed
- Freesmachines CNC



Luchttechniek

- Compressoren
- Luchtbehandeling
- Verwarmen
- Toebehoren



Slijp & schuurmachines

- Slijpmachines
- Bandschuurmachines
- Borenslijpers
- Afbraammachines
- Pijpslijpers



Draibanken

- Hobby
- Werkplaats
- Professioneel
- Industrieel Europees
- Teach in
- Draibanken petrochemie



Persen

- Handpersen
- Elektrische handpersen



Tapapparaten

- Pistool pneumatisch
- Pneumatisch
- Elektrisch/hydraulisch



Plaatbewerking

- Pijp- en strippenbuigers
- Pijpuitklinkers en uithoekers
- Rollenwalsen (+elektrisch)
- Profielwalsen
- Zetbanken
- Scharen elektrisch
- Scharen hydraulisch
- Handbediende scharen
- Kantbanken
- Ponsknipmachines



Zaagmachines

- Bandzagen draagbaar
- Bandzagen werkplaats
- Bandzagen industrie
- Bandzagen verticaal
- Cirkelzagen werkplaats
- Cirkelzagen industrie
- Aluminiumzagen
- Semi-automaat
- Volautomaat (+verstek)
- Dubbelkoloms (+verstek)
- Rollenbanen



Werkplaatsinrichting

- Werkplaatskasten
- Karren & transport
- Werkplaatstafels
- Materiaalkasten
- Accessoires



Toebehoren Metaal

- Stelvoeten
- Onderstellen
- Rollenbanen



Lassen

- MMA
- MIG-MAG
- SPOT
- TIG
- PLASMA
- Accessoires



Houtbewerking

- Afzuiginstallaties
- Schuurmachines
- Zaagmachines



Acculaders & omvormers

- Laders-starters
- Acculaders
- Starters
- Omvormers



Verspanende gereedschappen

- Frezen
- Boren
- Tappen
- Ruimen
- Draaien
- Zagen
- Stiffrezen
- Vijlen
- Slijpen & schuren
- Meten
- Tooling
- Koelen en smeren
- Machineaccessoires
- Veiligheid



Professioneel handgereedschap

- Professioneel
- Karren & koffers DIY



Metaalbewerking Huvema BlueLine

- Boormachines
- Boorfreesmachines
- Draaibanken
- Slijp-en schuurmachines
- Zaagmachines
- Afbraammachines
- Pijpenbuigers
- Persen
- Rollenwalsen

Goede prestaties beginnen met een professionele werkplaats!

In de Huvema webshop vindt u hoogwaardige industriële werkplaatsinrichting van Huvema Blue-Line. Professionele kwaliteit. Ideaal voor in de garage, werkplaats, loods, productie etc. Modern vormgegeven en robuust uitgevoerd in gepoedercoat, gelast staal.

Werkplaatskasten

Sterke stalen werkplaatskasten van A-kwaliteit. De kasten zijn perfect voor de bescherming en opslag van kleine materialen in de werkplaats en het magazijn. De laden openen geruisloos en gemakkelijk dankzij kogellagers. Kiepen wordt voorkomen doordat slechts één lade tegelijk kan worden geopend. In de ergonomische grepen van de lades kunt u labels plaatsen. De laden kunnen ver worden uitgetrokken, zodat kleine gereedschappen achterin gemakkelijk kunnen worden gepakt. Met verschillende sleuven aan de zijkanten van de lades is het gemakkelijk om de inrichting naar wens te veranderen. Deze kasten zijn perfect afgewerkt in RAL 5015 sky blue.



CNC Toolholder kasten

A-kwaliteit CNC kasten en toolholder kasten. Meest populair onder de gebruikers. Met gereedschapopnames, ideaal voor het opbergen van morseconus en CNC gereedschappen. Diverse uitvoeringen met inzetten voor gereedschaphouders. Computerkasten voor multifunctioneel gebruik. Uitgevoerd in de kleur RAL 5015 sky blue.

Computer- & industriekasten

Beste kwaliteit multifunctionele kasten voor gebruik in werkplaats, productie, fabriek etc. De deuren kunnen 180° worden geopend voor goede toegang en zijn voorzien van een veiligheidsslot. De laden en planken hebben een zeer groot draagvermogen. De kasten zijn uitgevoerd in RAL5015 sky blue.



Materiaalkasten

Sterke uitvoering, zeer geschikt voor de bescherming en opslag van materialen en onderdelen. Deze kasten worden veel gebruikt in werkplaatsen, bij bedrijven, magazijnen, productie, fabrieken en loodskantoren. Voor een goede toegang zijn de kasten voorzien van deuren die volledig geopend kunnen worden. Compleet uitgevoerd met ingebouwde ergonomische grip en cilindrisch veiligheidsslot. Afgewerkt in RAL 5015 sky blue. De kasten zijn verkrijgbaar in diverse uitvoeringen.

Lockerkasten

Oersterke lockers en garderobekasten. Ideaal voor gebruik in fabrieken, werkplaatsen, garages, kleedkamers etc. Stalen constructie met verborgen scharnieren. Deze degelijke en robuuste kasten zijn allemaal voorzien van sloten.





Bakkenrekken & -kasten

Stabiel plastic baksysteem, ideaal voor het slim opbergen van onderdelen en materialen. Handig voor het efficiënt organiseren van de werkruimte!



Werktafels

Praktische werkplaatstafels en werkbanken. Geschikt voor diverse werkomgevingen zoals service, onderhoud, productie, R&D, assemblage, werkplaats etc. De tafels zijn allemaal voorzien van rubberen matjes om de poten.

Mobiele werktafels

Eenvoudig verplaatsbare werktafels en werkbanken, met tafels van gegalvaniseerd staal/ RVS en MDF planken. Vaak gebruikt in garages en werkplaatsen voor het wegleggen van gereedschappen en apparatuur. Handig verrijdbaar dankzij de stevige rubberen wielen.



Wanden

Wanden van gaatjesboard voor het overzichtelijk ophangen van al uw gereedschappen, bakken etc. Bijpassende haken en ophangsystemen verkrijgbaar.



Gereedschap- & transportwagens

Hoogwaardige industriële gereedschapswagens. Ideaal voor in de garage of werkplaats. Handig om onderdelen, materialen, gereedschappen en apparatuur adequaat op te ruimen en weg te leggen.

Solide steekwagens, transportwagens en karren voor het makkelijk vervoeren en verplaatsen van goederen en materialen. Deze handige transporthulpmiddelen worden veel gebruikt in magazijnen, productieomgeving, logistiek, fabrieken en transport. Voorzien van ergonomische handgrepen en uitgevoerd in RAL5015 sky blue.

Archief- en legbordkasten

Sterke archiefkasten, perfect geschikt voor het opbergen van DIN A4 mappen etc. Uitgevoerd in de neutrale kleur RAL 7035 Light Grey. Hierdoor uitstekend passend bij elke kantoor, magazijn en projectinrichting.

Solide legbord- en legplanksystemen voor gebruik in bijvoorbeeld werkplaats en magazijn. Deze legbordstellingen en materiaalkasten zijn verkrijgbaar in diverse formaten. De legborden hebben een groot draagvermogen. Vervaardigd uit gegalvaniseerd staal.



Aluminiumproducten

Lichtgewicht werktafels, cnc toolholder kasten, computerkasten, bakkenrekken, schoonmaakkasten en transportwagens vervaardigd uit aluminium.

Accessoires

Handige universele accessoires voor gebruik in en op werkbanken, werkplaatstafels en werkplaatstafels.





VEILIGHEID

Veiligheid van de gebruiker is de topprioriteit bij het ontwerp en de fabricage van onze producten



LADEN VRIJWEL GEHEEL UITTREKBAAR

Zodat u ook de achterste gereedschappen gemakkelijk kunt pakken



LAADCAPACITEIT 80 KG

Alle laden in onze kasten hebben een laadcapaciteit van 80 kg



CENTRALE VERGREDELING

De centrale vergrendeling zorgt ervoor dat u uw spullen veilig op kunt bergen.



KWALITEITSCONTROLE

De kwaliteit van onze producten staat centraal vanaf het moment van ontwerp tot de fabricage



KLANTTEVREDENHEID

Door naar de wensen van onze gebruikers te luisteren kunnen wij de beste oplossingen bieden



2 JAAR GARANTIE

U krijgt 2 jaar garantie op alle producten



Werkplaatskasten



9

CNC Toolholder kasten



13

Computer- & industriekasten



15

Materiaalkasten



20

Lockerkasten



23

Bakkenrekken & -kasten



26

Werktafels



35

Mobiele werktafels



36

Wanden

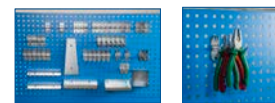

37

Gereedschaps- & transportwagens



38

Archief- & legbordkasten



41

Aluminiumproducten



44

Accessoires & onderdelen



45



Huvema[®]
BLUE-LINE

☎ 0413 34 22 75

Kennedylaan 14, 5466 AA Veghel, Nederland

WERKPLAATSKASTEN

Code:K1030



Code:K1031



Code:K1040



Code:K1041



Code:K1042



Code:K1060

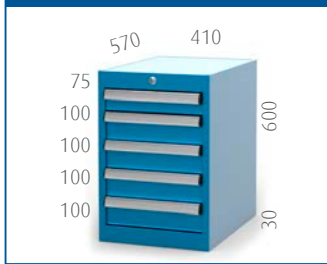

Code:K1061



Code:K1062



Code:K1070



Code:K1071



Code:K1072



Code:K1080



Code:K1081



Code:K1082



Code:K5030

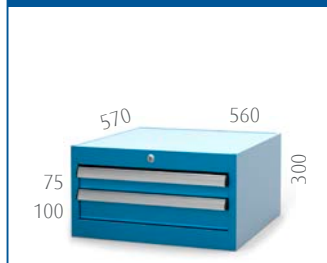

Code:K5031



Code:K5040



Code:K5041



Code:K5042



Code:K5060



Code:K5061



Code:K5062



Code:K5071



NIEUW

Code:K5072



NIEUW

WERKPLAATSKASTEN

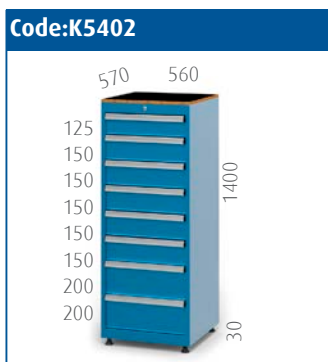
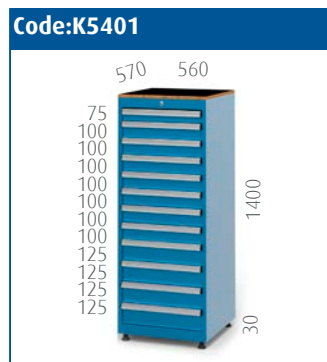

WERKPLAATSKASTEN



WERKPLAATSKASTEN

Code:K7400



Code:K7401



Code:K7402

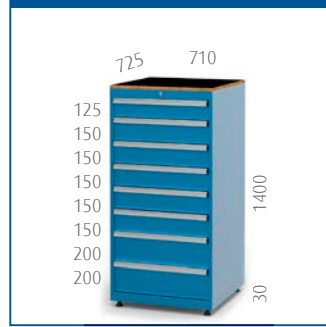

Code:K10080



Code:K10081



Code:K10082



Code:K10100



Code:K10101



Code:K10102



Code:K10200



Code:K10201



Code:K10202



Code:K11080



Code:K11081

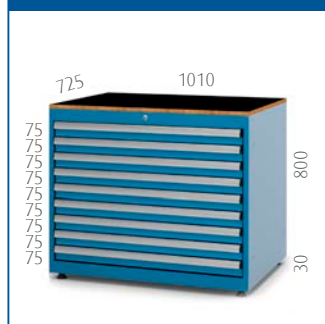

Code:K11082



Code:K11100



Code:K11101

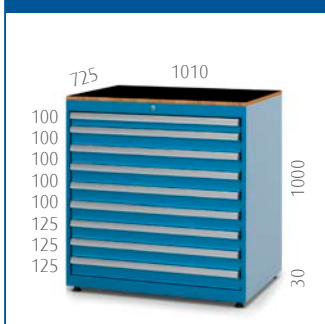

Code:K11102



Code:K11200

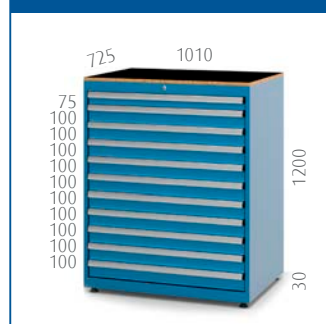

Code:K11201

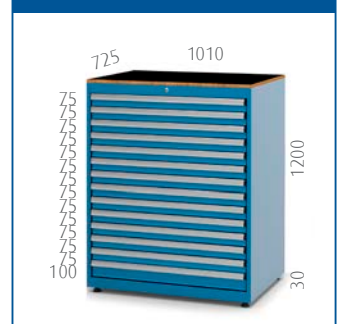

BAKKENREKKEN & -KASTEN



NIEUW

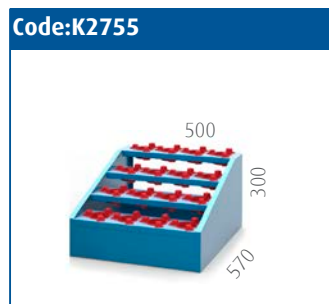



Huvema[®]
BLUE-LINE

☎ 0413 34 22 75

Kennedylaan 14, 5466 AA Veghel, Nederland

COMPUTER- & INDUSTRIEKASTEN

Code:K7441



Code:K7440



Code:K7442



Code:K7420



Code:K7435



Code:K7430



Code:K7445



NIEUW

Code:K7425



Code:K7422



NIEUW

Code:K5110



Code:K5150



Code:K7215



Code:K7110



Code:K6715



Code:K6800



Code:K6710



Code:K6720



Code:K6321



NIEUW

Code:K6316



NIEUW

Code:K6311



NIEUW



Huvema[®]
BLUE-LINE

☎ 0413 34 22 75

Kennedylaan 14, 5466 AA Veghel, Nederland

COMPUTER- & INDUSTRIEKASTEN





Huvema[®]
BLUE-LINE

☎ 0413 34 22 75

Kennedylaan 14, 5466 AA Veghel, Nederland

COMPUTER- & INDUSTRIEKASTEN



MATERIAALKASTEN

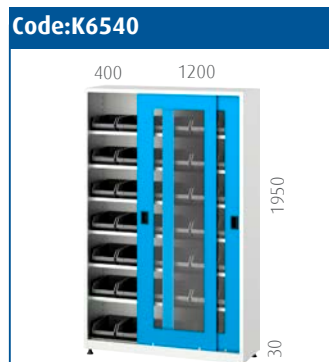

MATERIAALKASTEN





Huvema[®]
BLUE-LINE

☎ 0413 34 22 75

Kennedylaan 14, 5466 AA Veghel, Nederland

LOCKERKASTEN

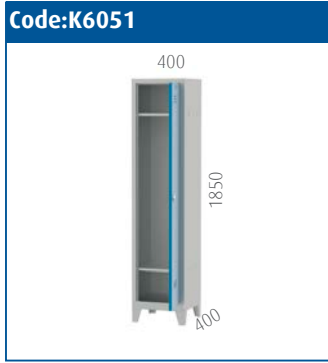

LOCKERKASTEN

Code:K6081

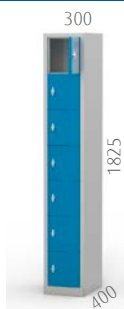

Code:K6082

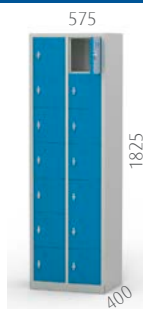

Code:K6062

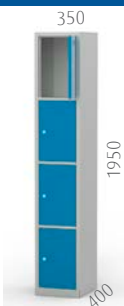

Code:K6063



Code:K6083



Code:K6084



Code:K6064



Code:K6061



BAKKENREKKEN & -KASTEN





BAKKENREKKEN & -KASTEN

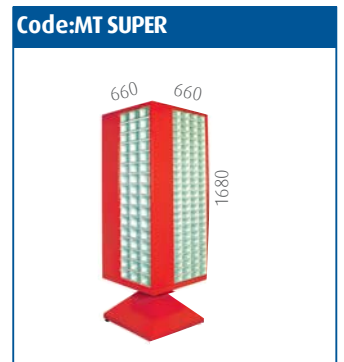



Huvema[®]
BLUE-LINE

☎ 0413 34 22 75

Kennedylaan 14, 5466 AA Veghel, Nederland

WERKTAfels

Code:K3325



Code:K3745



Code:K3750



Code:K3755



Code:K3655



Code:K3705



Code:K3700



Code:K3730



Code:K3715

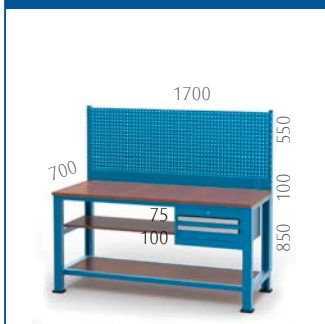

Code:K3650

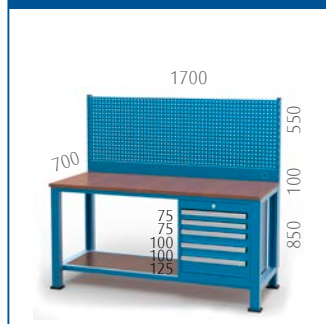

Code:K3710

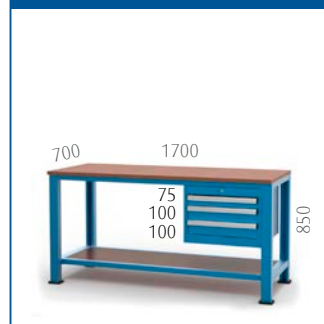

Code:K3775



Code:K3740

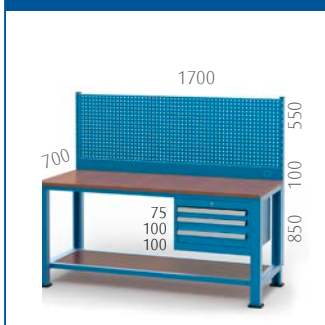

Code:K3350

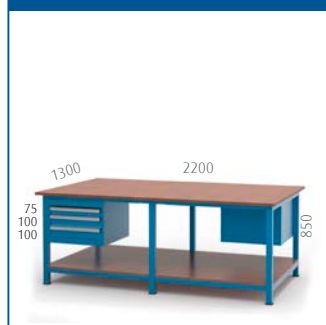

Code:K3170

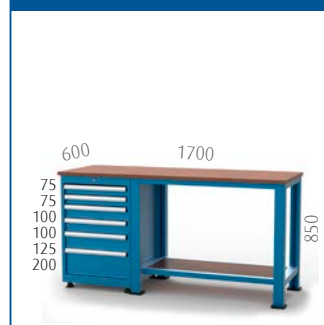

Code:K3185



Code:K3186



Code:K3685



Code:K3330



Code:K3310



WERKTAFELS



WERKTAfels

Code:K3606



Code:K3625

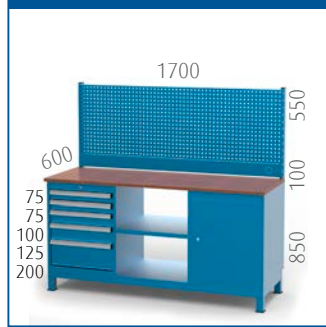

Code:K3622

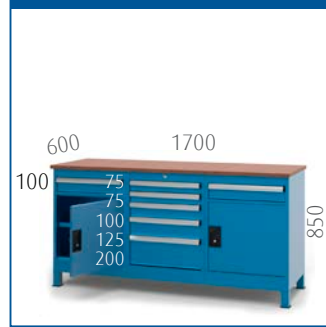

Code:K3600

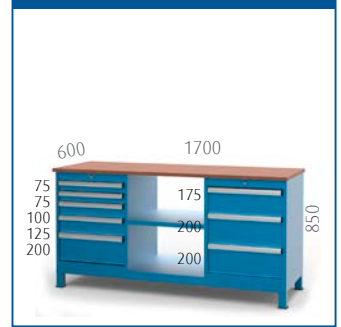

Code:K3605

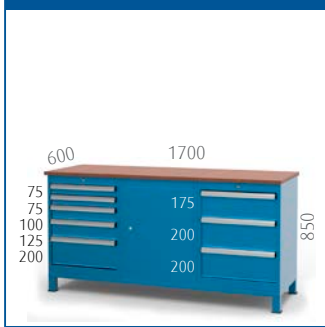

Code:K3610



Code:K3621



Code:K3590



Code:K3195



Code:K3540



Code:K3190



Code:K3460



Code:K3465



Code:K3918



Code:K3922



Code:K3921



Code:K3919



Code:K3941



Code:K3942



Code:K3943



WERKTAFELS

Code:K3936

NIEUW



Code:K3944



Code:K3945



Code:K3425



Code:K3530



Code:K3535



Code:K3526

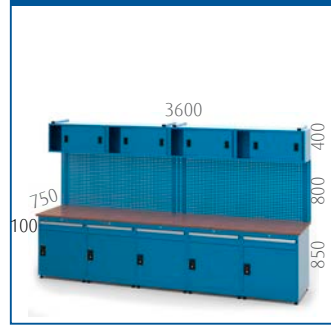

Code:K3515

NIEUW



Code:K3525

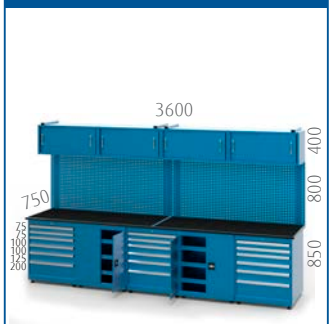

Code:K3510

NIEUW

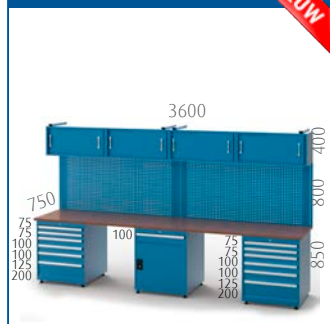

Code:K3520

NIEUW



Code:K3576



Code:K3475

NIEUW



Code:K3578



Code:K3577

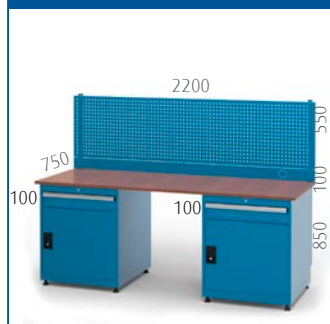

Code:K3495

NIEUW



Code:K3200



Code:K3575



Code:K3490

NIEUW



Code:K3470

NIEUW



Code:K3900



WERKTAFELS

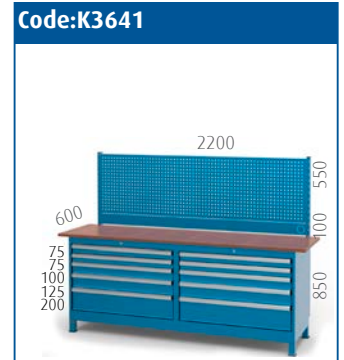



Huvema[®]
BLUE-LINE

☎ 0413 34 22 75

Kennedylaan 14, 5466 AA Veghel, Nederland

WERKTAFELS

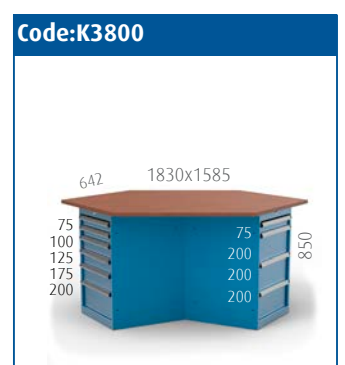

MOBIELE WERKTAFELS

Code:K8023



Code:K8030



Code:K8021



Code:K8027



Code:K8225



Code:K8230



Code:K8122



Code:K8019



Code:K8052



Code:K8051



Code:K8053



Code:K8017



Code:K8128



Code:K8129



Code:K8036



Code:K8038



Code:K8024



Code:K8026



Code:K8235



Code:K8034



WANDEN

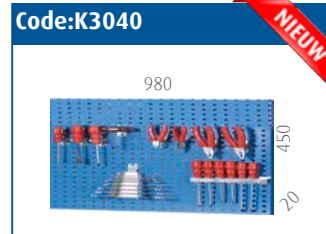
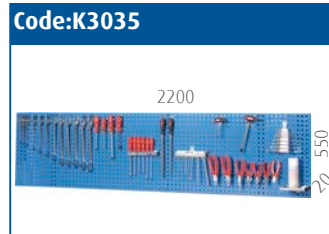
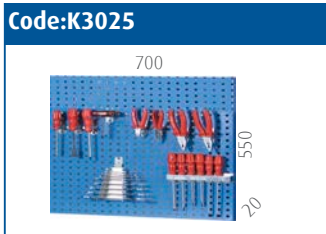
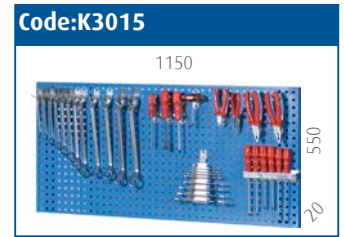
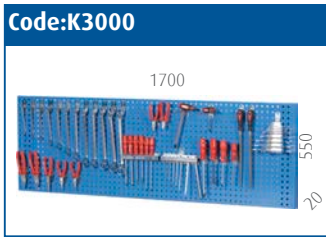

HAKEN

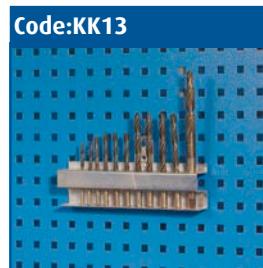
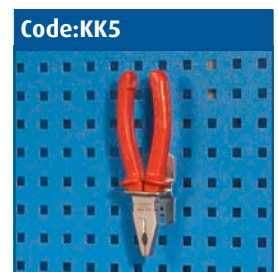
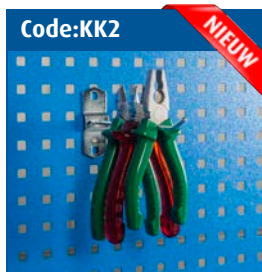

HAKENSETS

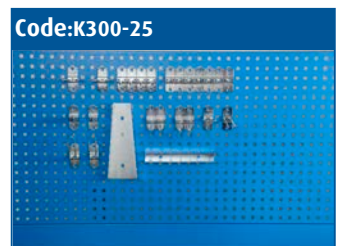
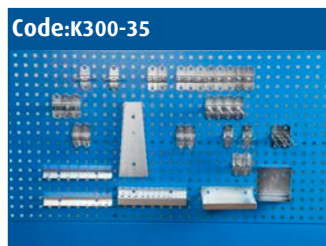
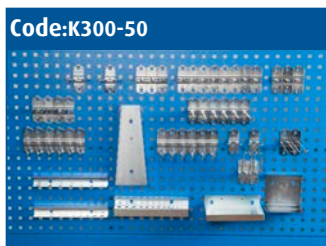
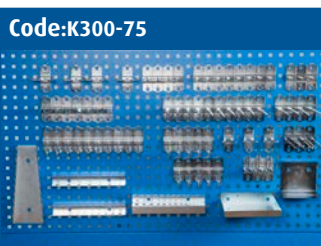

Set 75 stuks
 K1 : 15 stuks
 K2 : 14 stuks
 K3 : 7 stuks
 K4 : 10 stuks
 K5 : 3 stuks
 K6 : 3 stuks
 K7 : 3 stuks
 K8 : 10 stuks
 K9 : 1 stuk
 K10 : 1 stuk
 K11 : 1 stuk
 K12 : 1 stuk
 K13 : 1 stuk
 K14 : 1 stuk
 K15 : 4 stuks

Set 50 stuks
 K1 : 14 stuks
 K2 : 6 stuks
 K3 : 4 stuks
 K4 : 6 stuks
 K5 : 2 stuks
 K6 : 2 stuks
 K7 : 2 stuks
 K8 : 6 stuks
 K9 : 1 stuk
 K10 : 1 stuk
 K11 : 1 stuk
 K12 : 1 stuk
 K13 : 1 stuk
 K14 : 1 stuk
 K15 : 2 stuks

Set 35 stuks
 K1 : 10 stuks
 K2 : 4 stuks
 K3 : 3 stuks
 K4 : 2 stuks
 K5 : 2 stuks
 K6 : 2 stuks
 K7 : 2 stuks
 K8 : 2 stuks
 K9 : 1 stuk
 K10 : 1 stuk
 K11 : 1 stuk
 K12 : 1 stuk
 K13 : 1 stuk
 K14 : 1 stuk
 K15 : 2 stuks

Set 25 stuks
 K1 : 7 stuks
 K2 : 4 stuks
 K3 : 2 stuks
 K4 : 2 stuks
 K5 : 1 stuks
 K6 : 1 stuks
 K7 : 2 stuks
 K8 : 2 stuks
 K10 : 1 stuk
 K11 : 1 stuk
 K15 : 2 stuks

GEREEDSCHAPS- & TRANSPORTWAGENS



GEREEDSCHAPS- & TRANSPORTWAGENS

Code:K4070



1000x600x720

Code:K4160



550x400x1450

Code:K4125



690x530x1400

Code:K4150



640x480x1250

Code:K4215



850x650x850

Code:K4200



680x800x1420

Code:K4230



1000x700x380-950

Code:K4225



1000x700x180-950

Code:K4235

NIEUW



1000x700x180-950

Code:K4440

NIEUW



1000x700x180-950

Code:K4445

NIEUW



1000x700x180-950





Huvema[®]
BLUE-LINE

☎ 0413 34 22 75

Kennedylaan 14, 5466 AA Veghel, Nederland

ARCHIEF- & LEGBORDKASTEN



Code:K20931



Code:K20943



Code:K20959



Code:K25931



Code:K25943



Code:K25959



Code:K20939



Code:K20949



Code:K20925



Code:K20935

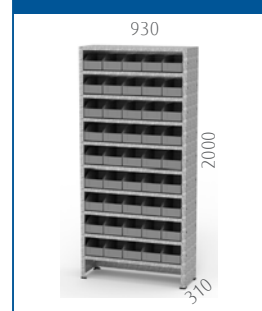

Code:K20920

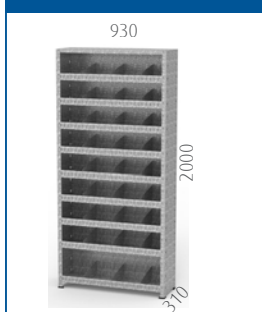

Code:K20940 **NIEUW**



Code:K20950 **NIEUW**



Code:K20945 **NIEUW**



Code:K20955 **NIEUW**





Huvema[®]
BLUE-LINE

☎ 0413 34 22 75

Kennedylaan 14, 5466 AA Veghel, Nederland



ALUMINIUMPRODUCTEN

Code:K98122

NIEUW



Code:K93321

NIEUW



Code:K93315

NIEUW



Code:K93310

NIEUW



Code:K98039

NIEUW



Code:K97441

NIEUW



Code:K92200

NIEUW



Code:K93945

NIEUW



Code:K94082

NIEUW



Code:K94071

NIEUW



Code:K94225

NIEUW



Code:K94900

NIEUW



Code: TS1765



Tafelblad gelamineerd hardboard

Code: TK1770

Code: TK1760

Code: TK2260



Tafelblad spaanplaat

Code: PVC1770

Code: PVC1760

Code: PVC2260

Code: PVC1257

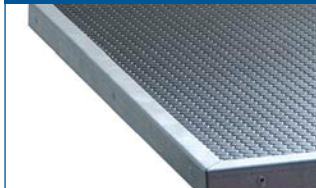

PVC-coating

Code: GZT1770

Code: GZT1760

Code: GZT2260

Code: GZT1257

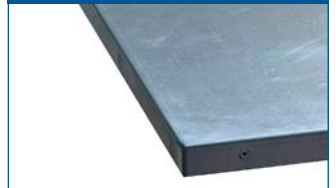

Tafelblad gegalvaniseerd metaal

Code: MDF1770

Code: MDF1760

Code: MDF2260

Code: MDF1257



Tafelblad MDF

Code: INOX1770

Code: INOX1760

Code: INOX1257



Tafelblad RVS

Code: ESD1770



Tafelblad ESD, finish mat

Code: MSF1770

Code: MSF1760



Solide houten tafelblad

Code: FTX-170

Verlichtingssysteem 1700mm



Code: EP15

Code: EP12

Elektrische aansluitingen



Code: FTX-120

Verlichtingssysteem 1200mm



Code: HJK4

Luchtaansluiting, 4-weg



Code: KM125

Klem 125mm



Code: KM150

Klem 150mm



Code: UK10

Haspel 10 m



Code: SDD900

Archiefkast met schuifdeuren 900 mm

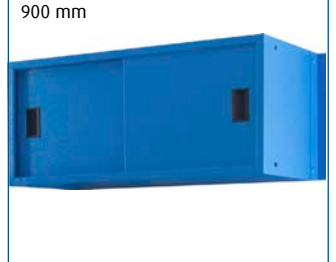

Code: AVR17

Plank voor kunststof bakken 1700 mm



Code: AVR500

Plank voor kunststof bakken 500 mm



Code: AVR980

Plank voor kunststof bakken 980 mm

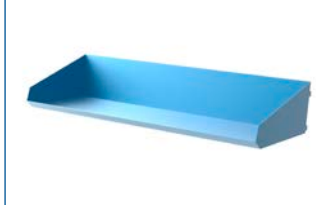

Code: AVS980

Rail voor kunststof bakken A-150



Code: KTT100

Weilenset diameter 100 mm



Code: KTT125

Wielenset diameter 125 mm



Code: PU100

Polyamide wielenset met polyurethaan-coating diameter 100 mm



Code: PU125

Polyamide wielenset met polyurethaan-coating diameter 125 mm





19 °C

Huvema **UCE**
Focus op Metaal

↑ Expeditie
← Kantoor

GOEDE PRESTATIES BEGINNEN MET EEN PROFESSIONELE WERKPLAATS

Bij Huvema vindt u hoogwaardige
industriële werkplaatsinrichting van
Huvema Blue-Line.

Professionele kwaliteit. Ideaal voor in de
garage, werkplaats, loods, productie etc.

Modern vormgegeven en robuust
uitgevoerd in gepoedercoat, gelast staal.

Huvema[®]
BLUE-LINE

☎ 0413 34 22 75

Kennedylaan 14, 5466 AA Veghel, Nederland

